

## The Ten-Year Solution

### LED Illuminator for ALL JERGUSON® Glass Level Gages

- High Contrast  
- Superior Visibility Day or Night
- Maintenance FREE
- Long Life ~100,000 hrs.
- No Heat Generation
- Field Upgradable  
- Fits any glass gage!
- Eliminates “bulb-changes”
- Longest Field-of-View
- Covers up to 4 Size 9 Gage Sections
- Explosion-Proof Power Supply, Intrinsically Safe Lighting Circuit
- Pays for itself in electricity savings alone!



#### SPECIFICATIONS

Power Supply:	120 or 240 VAC @ 50-60 Hz
Power Consumption:	< 750 mA @120 VAC < 375 mA @ 240 VAC
Est. Life:	100,000 Hours (continuous)
Agency Approvals:	FM Approved, CSA Pending Class I, Div I, Grps. B, C, & D Class II, Div I, Grps. E, F, & G
Wire Size:	Min 18 AWG / Max 12 AWG
Max Distance From Power Supply to Light Strip:	8 ft (2.5m)
Ambient Temperature:	-40 F (-40 C) to 170 F (77 C)
Electrical Connection:	½" FNPT

JERGUSON® is pleased to announce the addition of the LED Gage Glass Lumenator II to the world's largest selection of level indication and control products. JERGUSON's model EPL-100 is approved for use in Class I, Div I, Group B, C & D environments. Available in any size up to 55" long with a single power supply. That means a four section, size nine gage from a single power supply at less than 750 mA! Contact your local representative or a Jerguson Applications Engineer to configure an EPL-100 for your transparent glass level gages.

# JERGUSON® LED Gage Glass Lumenator II™ EPL-100

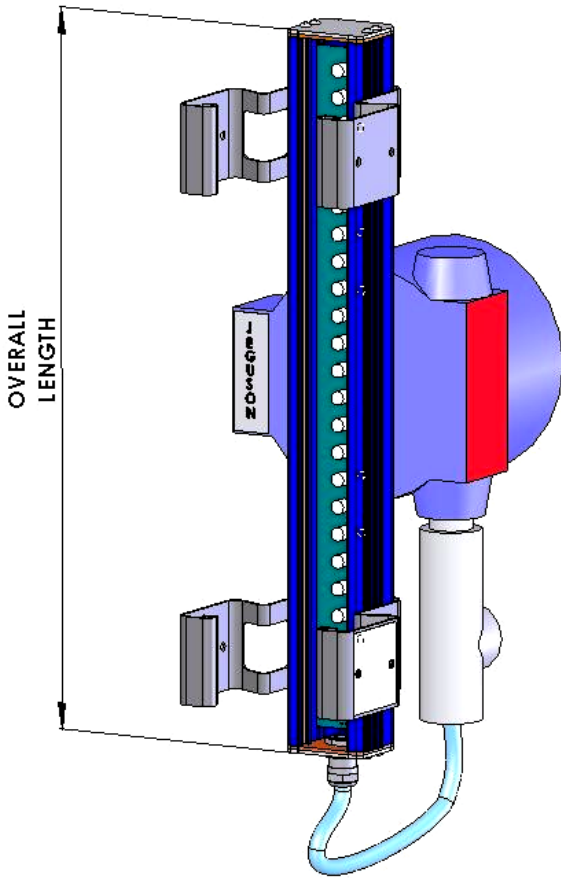

Lumenator II™ Model		Overall Length		
Series 20	Series 300L	Inches	mm	lbs
EPL-100-11		5 1/4	133	5.4
EPL-100-12		5 1/4	133	5.4
EPL-100-13		7 1/4	184	5.6
EPL-100-14		7 1/4	184	5.6
EPL-100-15		9 1/4	235	5.7
EPL-100-16	EPL-100-111	11 1/4	286	5.9
EPL-100-17		11 1/4	286	5.9
EPL-100-18	EPL-100-112	13 1/4	337	6.1
EPL-100-19	EPL-100-113	13 1/4	337	6.1
EPL-100-23	EPL-100-115	15 1/4	387	6.3
EPL-100-24		17 1/4	438	6.4
EPL-100-25	EPL-100-118	19 1/4	489	6.6
EPL-100-26	EPL-100-120	21 1/4	540	6.8
EPL-100-27	EPL-100-211	23 1/4	591	6.9
	EPL-100-212	25 1/4	641	
EPL-100-28	EPL-100-213	27 1/4	692	7.3
EPL-100-29		29 1/4	743	7.4
EPL-100-36	EPL-100-215	31 1/4	794	7.6
EPL-100-37	EPL-100-311	35 1/4	895	7.9
	EPL-100-218	37 1/4	946	
EPL-100-38	EPL-100-312	39 1/4	997	8.3
EPL-100-39	EPL-100-220 / EPL-100-313	41 1/4	1048	8.5
EPL-100-47	EPL-100-315	47 1/4	1200	9.0
EPL-100-48		53 1/4	1353	9.5
EPL-100-49	EPL-100-318	57 1/4	1454	9.9
EPL-100-57		59 1/4	1505	10.1

To Specify a LED Gage Glass Lumenator II™ on a JERGUSON® Level Gage:

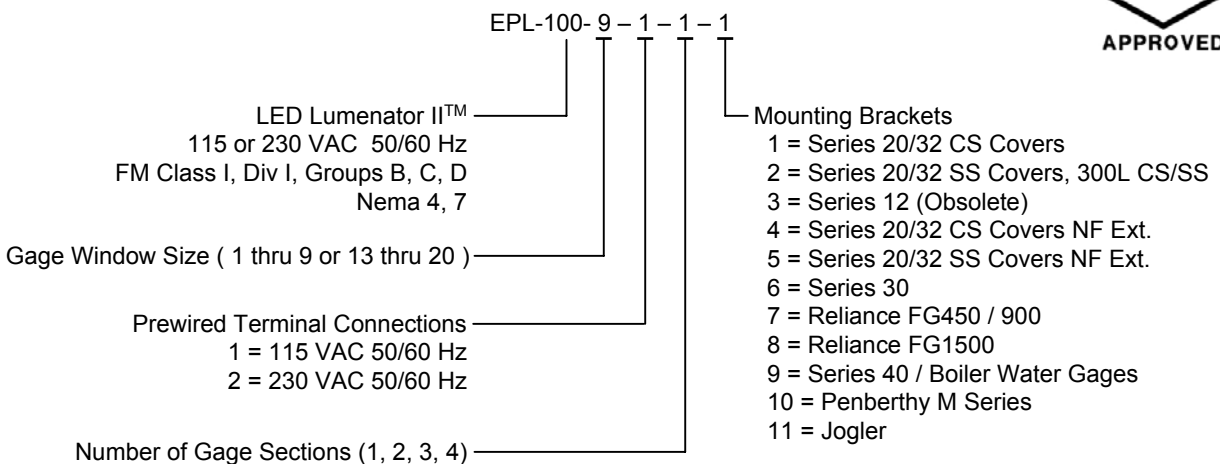

Aftermarket Services



Products Manufactured by the Clark-Reliance® Corporation  
16633 Foltz Industrial Pkwy., Strongsville, OH 44149 USA  
Telephone: (440) 572-1500 Fax: (440) 238-8828  
www.clark-reliance.com sales@clark-reliance.com

