

# JERGUSON®

Specialists in Liquid Level Indication & Control

## LevelStar Magnicator II® Bi-Color LED Level Indicator

Section: M100  
Bulletin: M100.120  
Date: 7/04  
Supersedes: 10/03

# THE **BRIGHTEST IDEA** IN LEVEL INDICATION

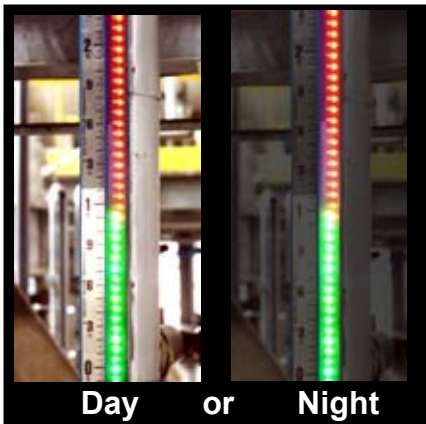

MAGNIFICATOR II®  
Shown with  
LevelStar Bi-Color LED Illuminator

## LevelStar Magnicator II® Bi-Color LED Level Indicator

- High Contrast  
- Superior Visibility Day or Night
- Increased Reliability
- Long Life (over 70,000 hrs.)
- No Mechanical / Rotating Parts
- Field Upgradable
- Customized Color Options
- Longest Field-of-View Available

JERGUSON® is pleased to announce the addition of the Magnicator II® Bi-Color Level Indicator to the world's largest selection of level indication and control products. The Magnicator's level lights utilize patent pending technology to deliver unmatched visibility and reliability throughout your plant.

JERGUSON ....Quality, Safety and Performance.

# LevelStar Magnicator II<sup>®</sup> Bi-Color LED Level Indicator\*

## SPECIFICATIONS

Input Voltage:	120VAC / 240VAC
Indicator Voltage:	- 18 VDC
Power Consumption:	700 mA max. @ 20 feet indication
Ambient Temp.:	175 F
Process Temp.:	375 F w/o insulation strip 450 F with insulation strip 451+ F with air purge
Wire Spec:	14 AWG nominal 16 AWG max.
Max. Distance From Power Supply to Light Strip:	4 feet
Electrical Conn.:	3/4" FNPT
Estimated Life:	100,000 Hours (continuous)
Agency Approvals:	FM Approved, CSA Pending Class I, Div I, Grps. B, C, & D Class II, Div I, Grps. E, F, & G

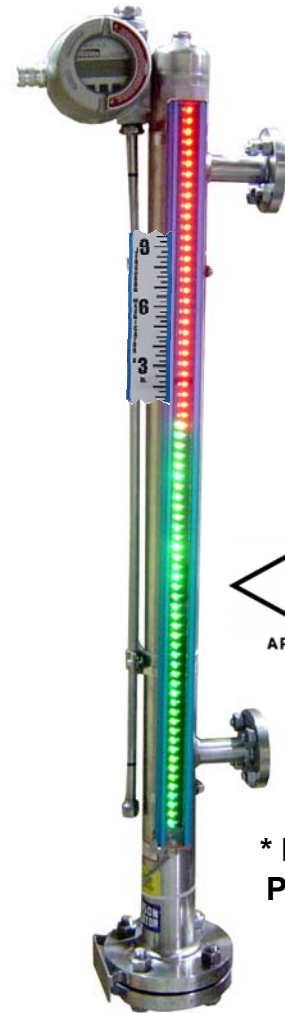

**\* PATENT  
PENDING**

### MAGNICATOR II<sup>®</sup>

Shown with  
LevelStar Bi-Color LED Illuminator  
and Magnetostrictive transmitter

To Specify a Bi-Color LED Level Indicator on a  
MAGNICATOR II<sup>®</sup> Level Gage:

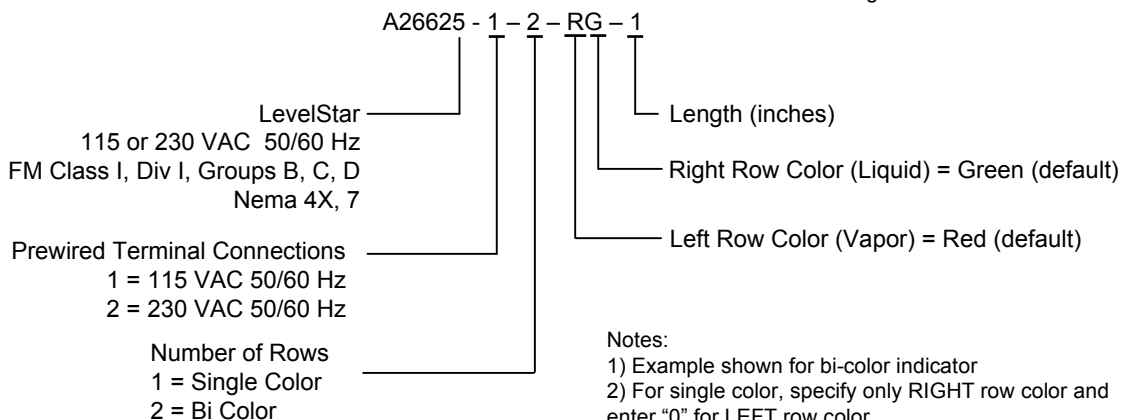

Aftermarket Services

# JERGUSON<sup>®</sup>

Products Manufactured by the Clark-Reliance<sup>®</sup> Corporation  
16633 Foltz Industrial Pkwy., Strongsville, OH 44149 USA  
Telephone: (440) 572-1500 Fax: (440) 238-8828  
www.clark-reliance.com sales@clark-reliance.com

